



# ESYBOX MAX

PRODUCT INFORMATION |

# A NEW ERA



# FEATURES



VFD

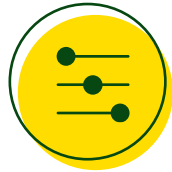

Expansion  
Vessel



Pump



Sensors



NRV



# ALL INTEGRATED

# PERFORMANCE

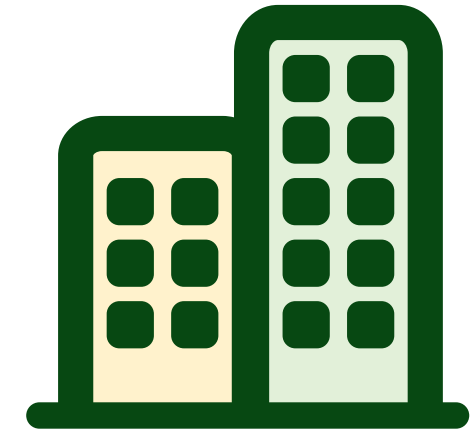
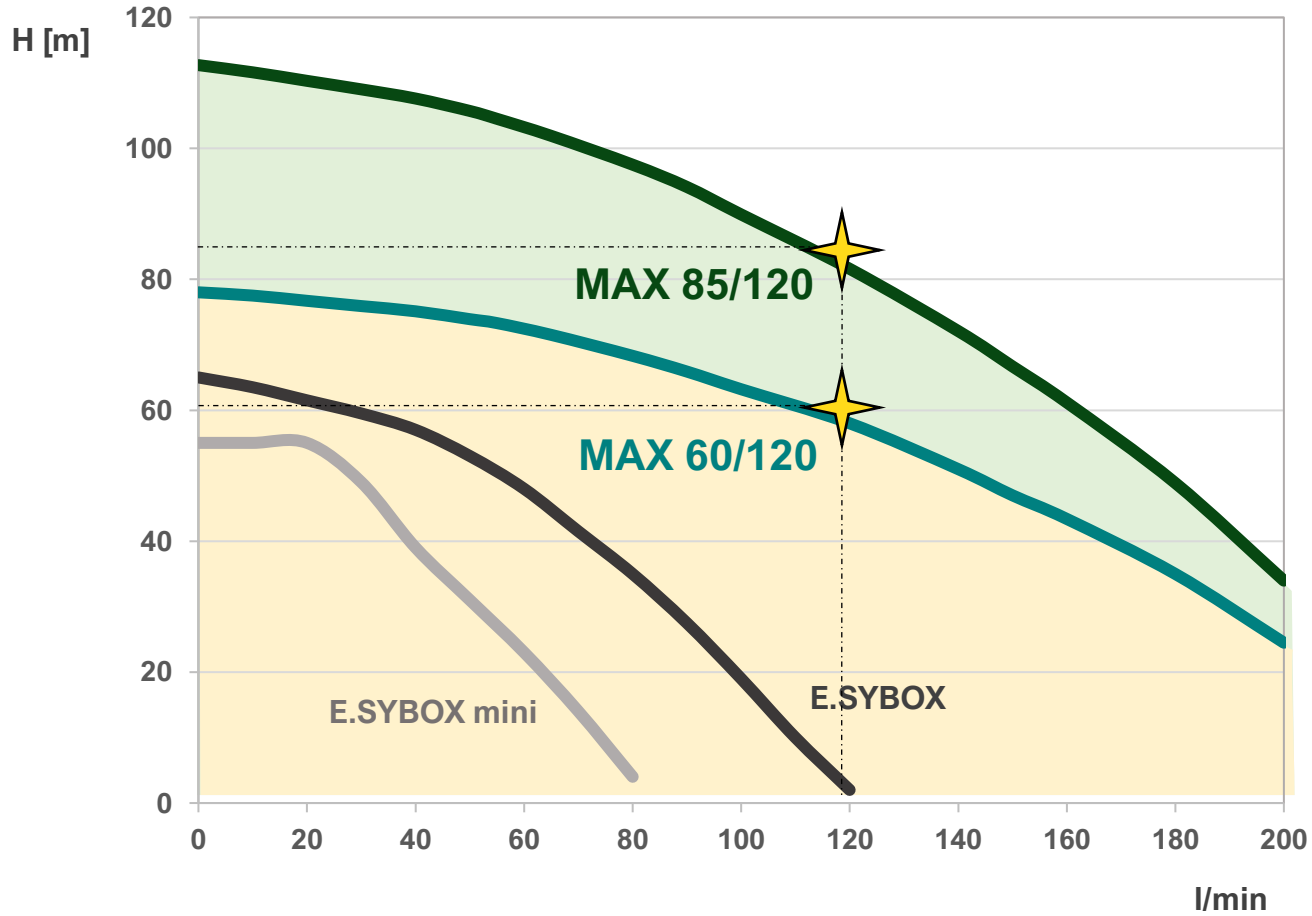

**60/120 M/T**

Up to 8 floors  
and 20 apartments

**85/120 T**

Up to 14 floors and  
20 apartments

# MODULARITY



2



3

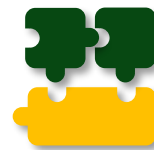

2+2



# PERFORMANCE

**85/120 T**  
max head = 113 m

**60/120 M/T**  
max head = 80 m

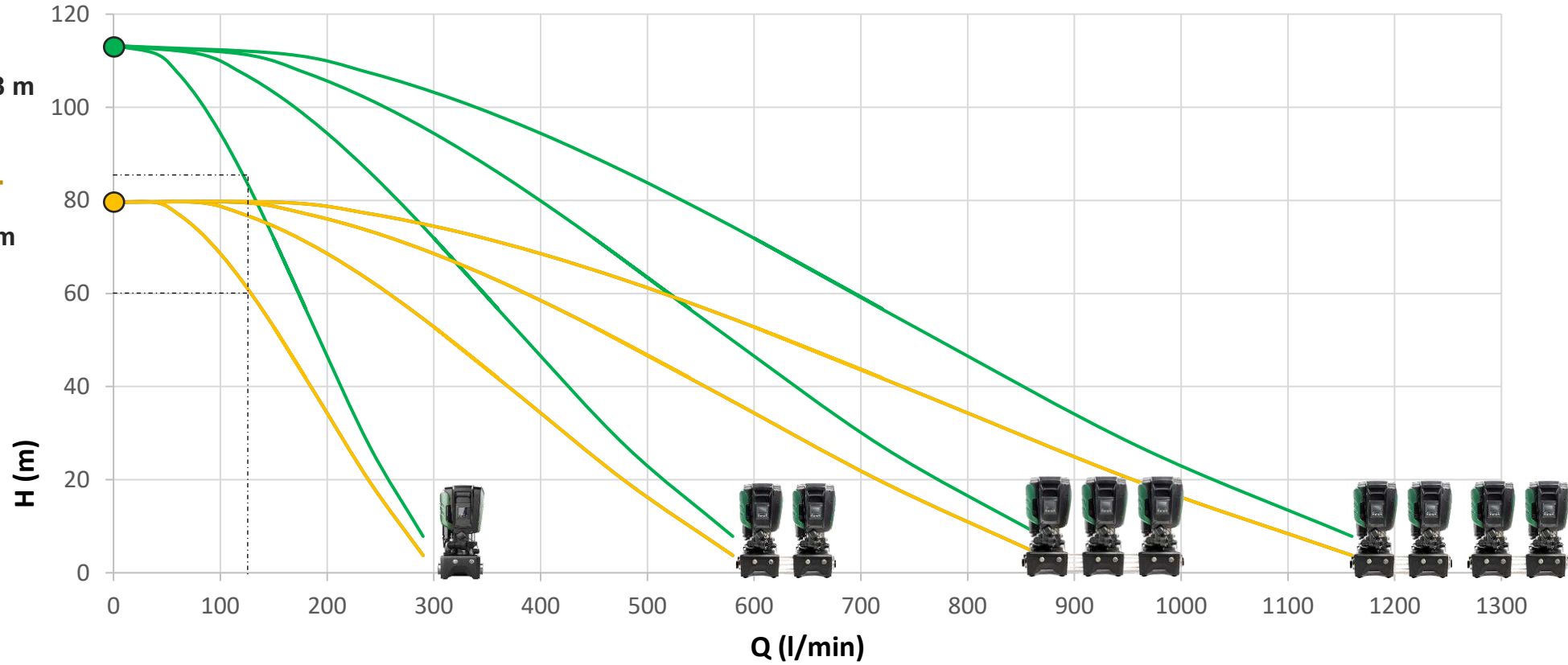



# Comfort Energy Saving

KVCE vs ESYBOX MAX 85/120

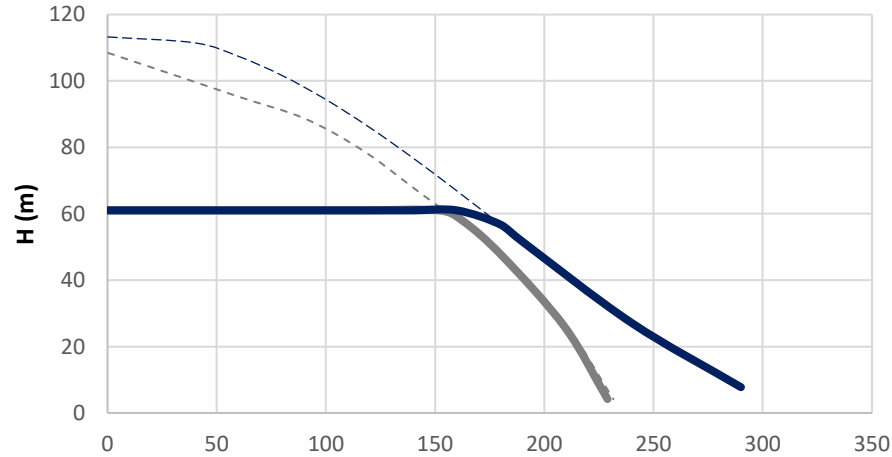

On/Off  
Pump

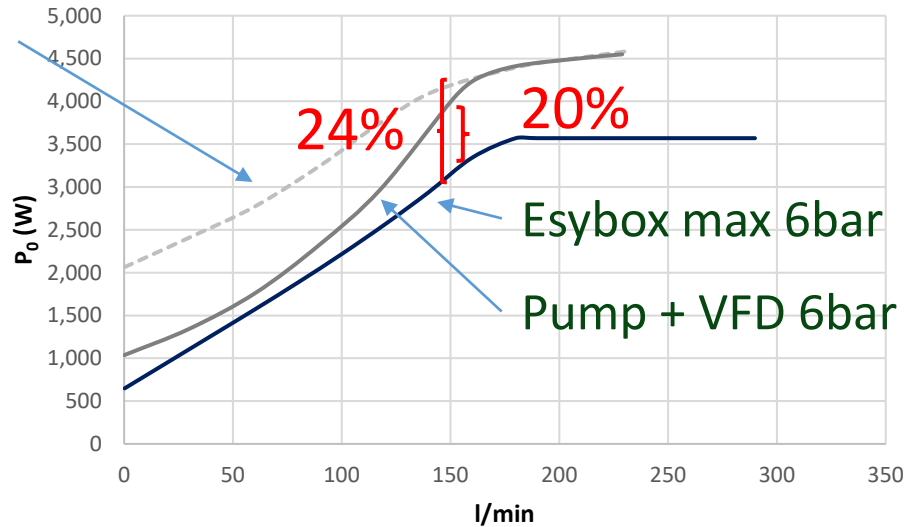

**PERMANENT  
MAGNET  
MOTOR**



**HIGH  
EFFICIENCY  
HYDRAULICS**

energy saving	vs Pump+ VFD	Vs On/Off Pump
DAILY	2.8 kWh	12.2 kWh
ANNUAL	1.038 kWh	4.461 kWh

 **Comfort  
Silence**



**WATER  
COOLED  
MOTOR**



**ESYBOX MAX**

A little more than a **conversation**

**63 dB** (50 l/min @ 6 bar)

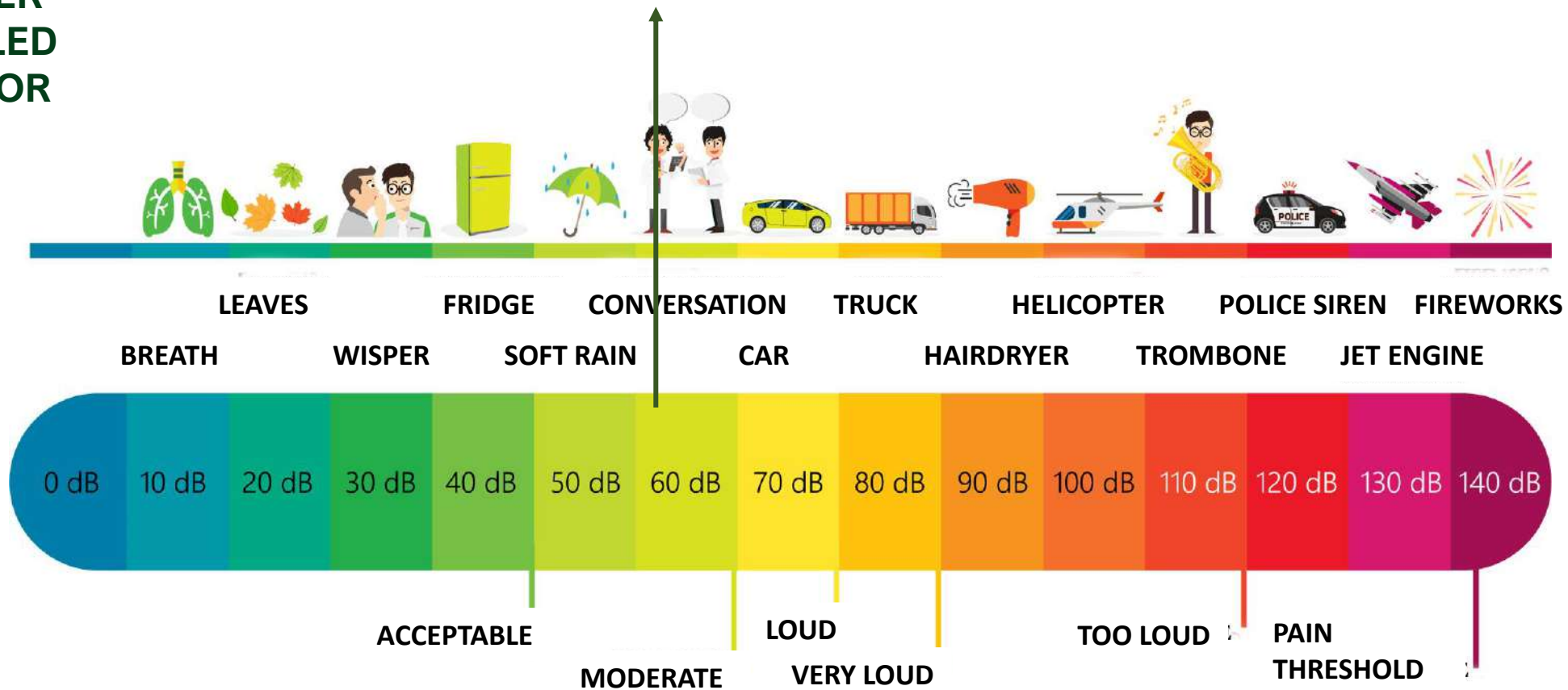



**ENGINEER**



**Modular**

**WHOLESALER**



**Space-saving**

**INSTALLER**



**Lightweight, on  
site assembly**

**MAINTAINER**



**Connected**

**CUSTOMER**



**Adjustable**

**ENVIRONMENT**



**Recycled  
materials**



## **SIMPLER MAINTAINANCE**

Modular and functional construction. The modular components of the pump make it easier to perform maintenance. The parts can be removed, repaired and replaced separately, simplifying the resolution of any issues and reducing maintenance costs.

# EASY TO STORE



**VS**



**BEFORE**

**AFTER**

# OUR PROPOSAL



TRANSPORTATION



HANDLING



Size



375 x 750 x 375 mm

Weight



31 Kg

Packaging

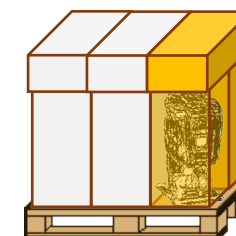

6 PCs/pallet



esybox DIVER



esybox MAX

**DAB**<sup>®</sup>

WATER • TECHNOLOGY

Esybox Max is an integrated pumping system for water pressurization in commercial building service. It is composed of modular elements that allow different configurations: single, double, triple or quadruple system are possible, to cover the needs of medium/large condominiums and high buildings. The innovative support base of the pumping unit and the wireless communication between the pumps make it possible to assemble the unit directly at the installation site even by one person.

MAC Design, DAB Pumps, style, innovation, quality and technology: right ingredients to win the IF design award in 2021!



EACH UNIT CONSISTS OF THE HYDRAULIC CONNECTION BASE AND THE PUMPING UNIT WHICH INCLUDES:

- ELECTRONIC VERTICAL MULTI-IMPELLER PUMP
- DISPLAY
- WI-FI MODULE
- PRESSURE SENSORS
- NON-RETURN VALVE ON DELIVERY
- EXPANSION TANK

## CONCEPT DESIGN Sketches

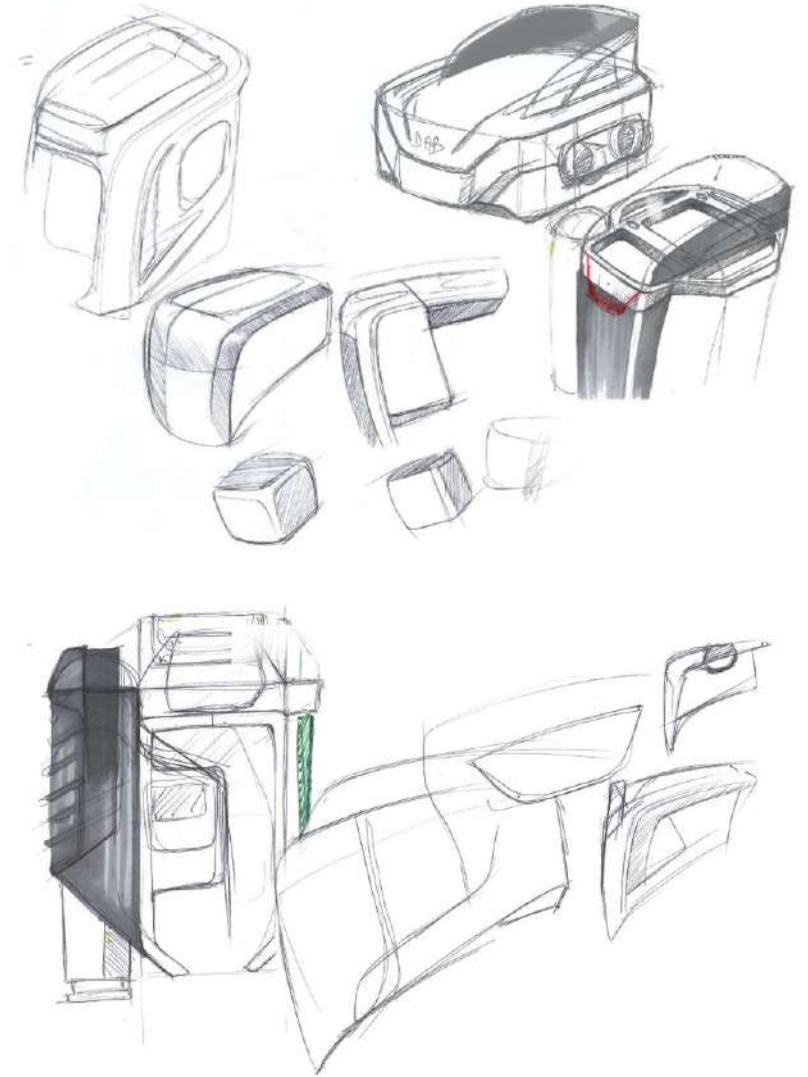

**CONCEPT DESIGN**  
*Moodboard Inspiration*

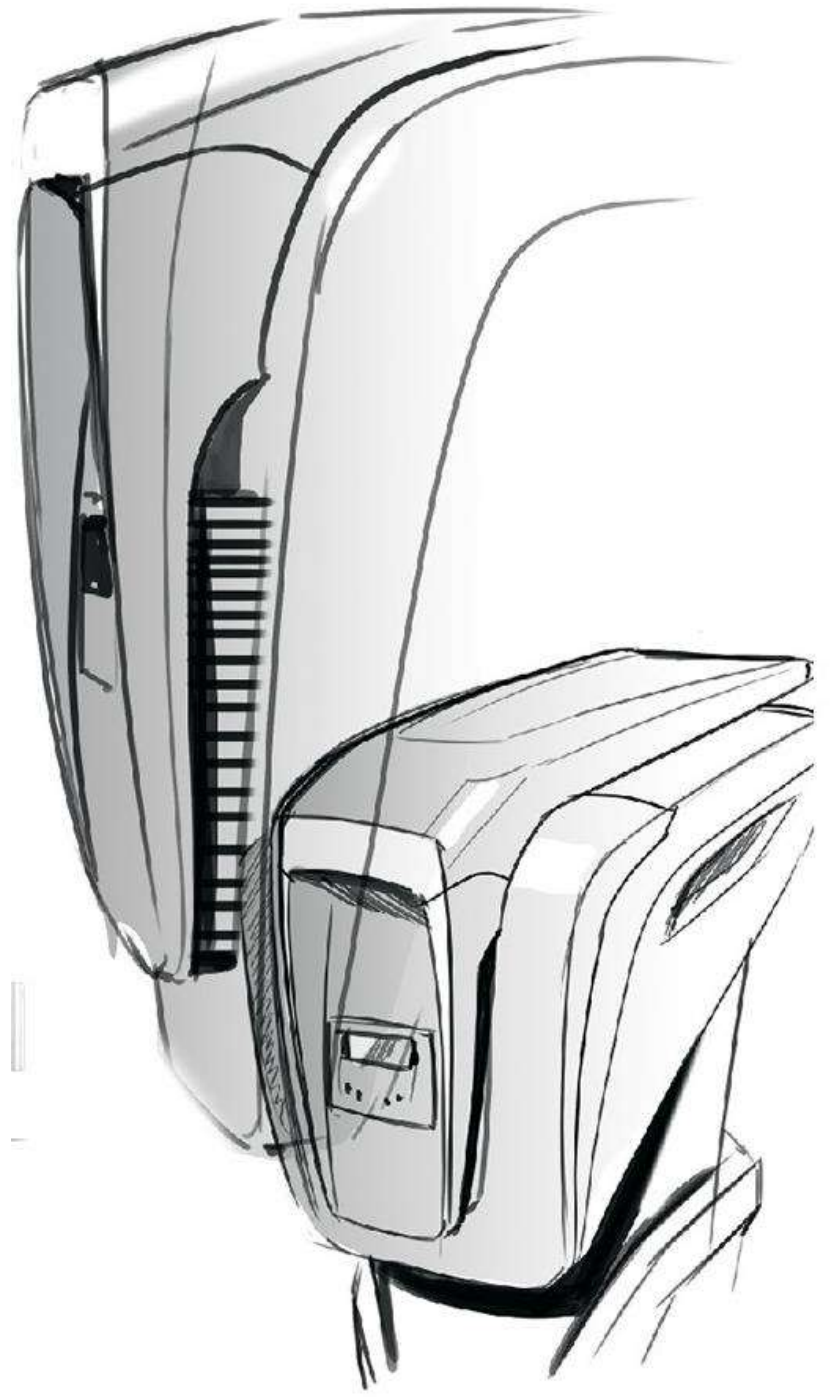
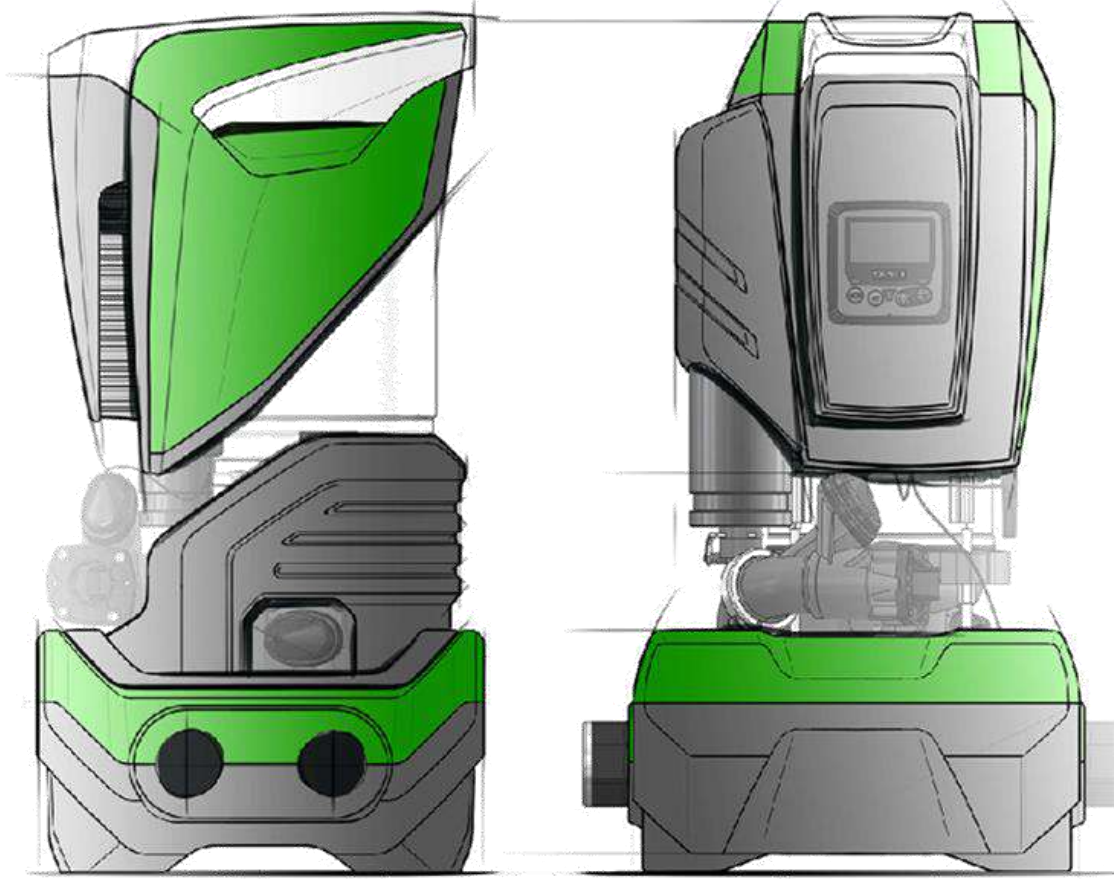

# TECHNICAL FEATURES



# TECHNICAL SHEET

Text	Parameter		ESYBOX MAX 60/120M	ESYBOX MAX 60/120T	ESYBOX MAX 85/120T	
ELECTRIC POWER SUPPLY	Voltage		208-240	380/480	380/480	
	Phases		1	3	3	
	Frequency		50/60			
	Maximum current		11,8 A	4,2 A	5,5 A	
	Maximum power		2,68 KW	2,65 KW	3,5 KW	
	Leakage current to earth		<2 mA	<4 mA	<4 mA	
CONSTRUCTION CHARACTERISTICS	Overall dimensions		766x375x384			
	Empty weight (excluding packaging)	PUMP	29	29	30	
		ESYDOCK		9		
		2 ESYDOCK		18		
		3 ESYDOCK		27		
	Protection class		IPX5			
Motor insulation class		F				
HYDRAULIC PERFORMANCE	Maximum head		7,7bar	7,7bar	10bar	
	Maximum pressure at intake		5 bar			
	Maximum working pressure (PN)		12 bar			
	Maximum flow rate		300 l/min			

## SUCTION CAPABILITY

2

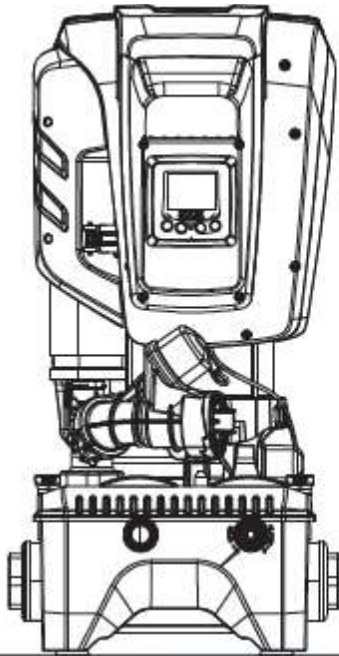

Max 55°C - 131°F



0°C + 50°C  
32°F + 122°F

## OUTDOOR INSTALLATION



# PRESSURE TANK

5

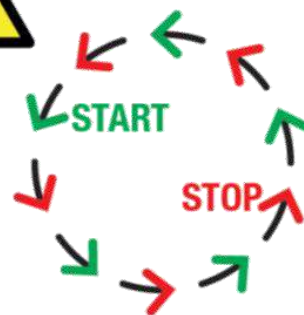
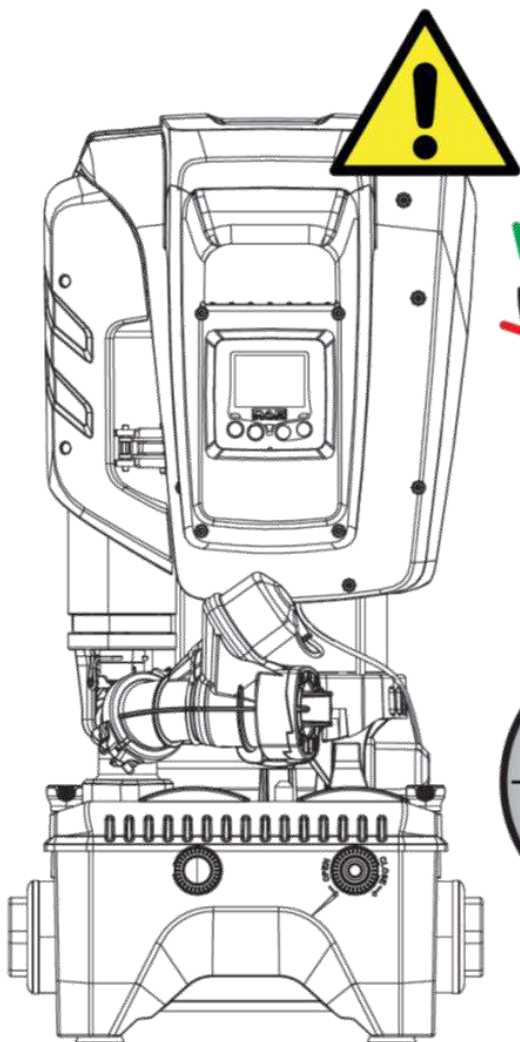
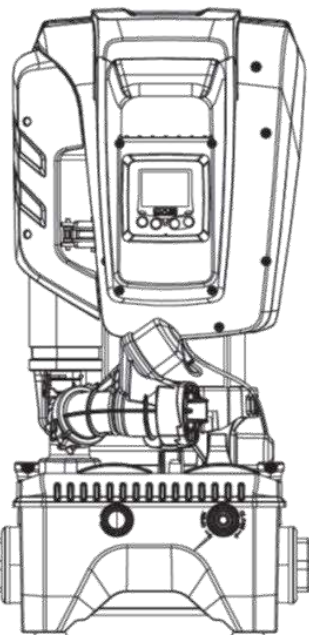

**MAX 30  
START**

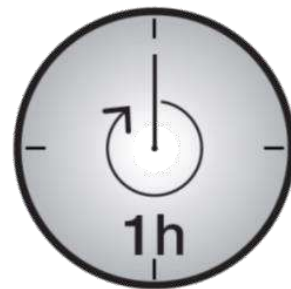

# EXPANSION VESSEL

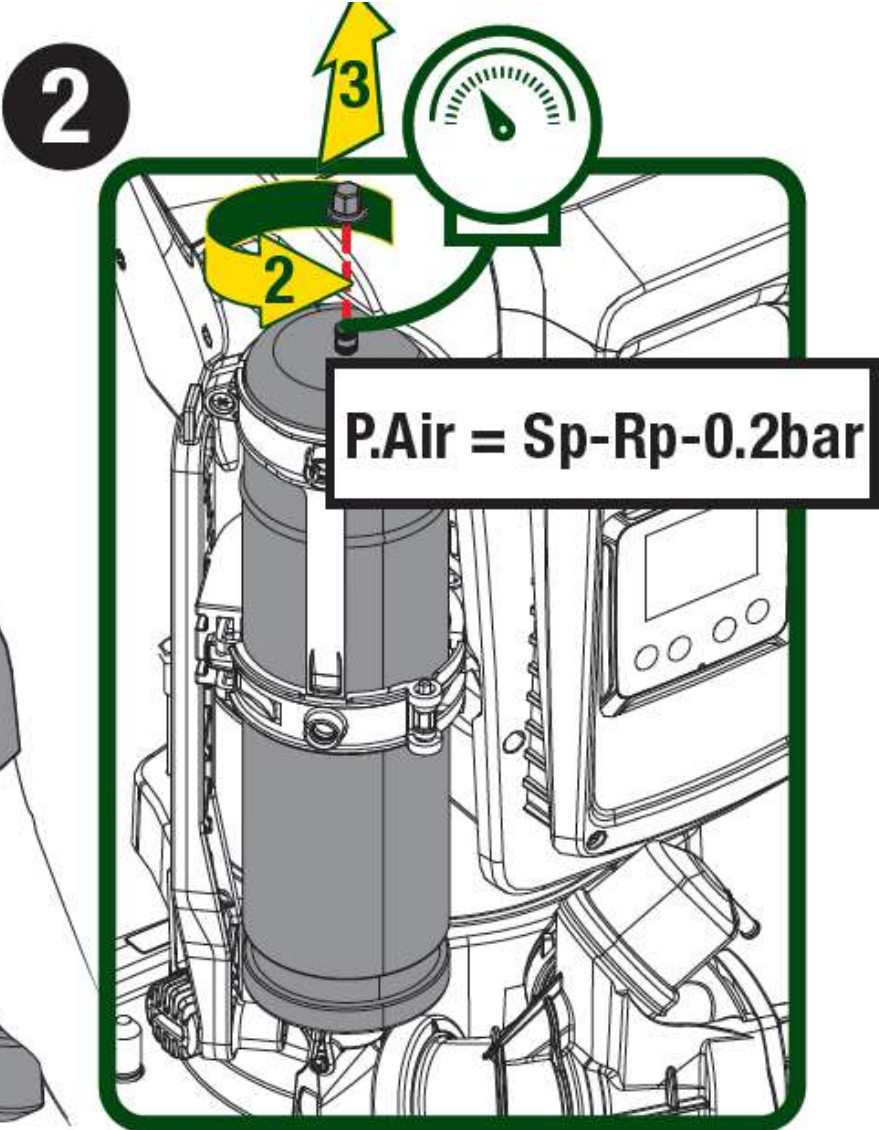
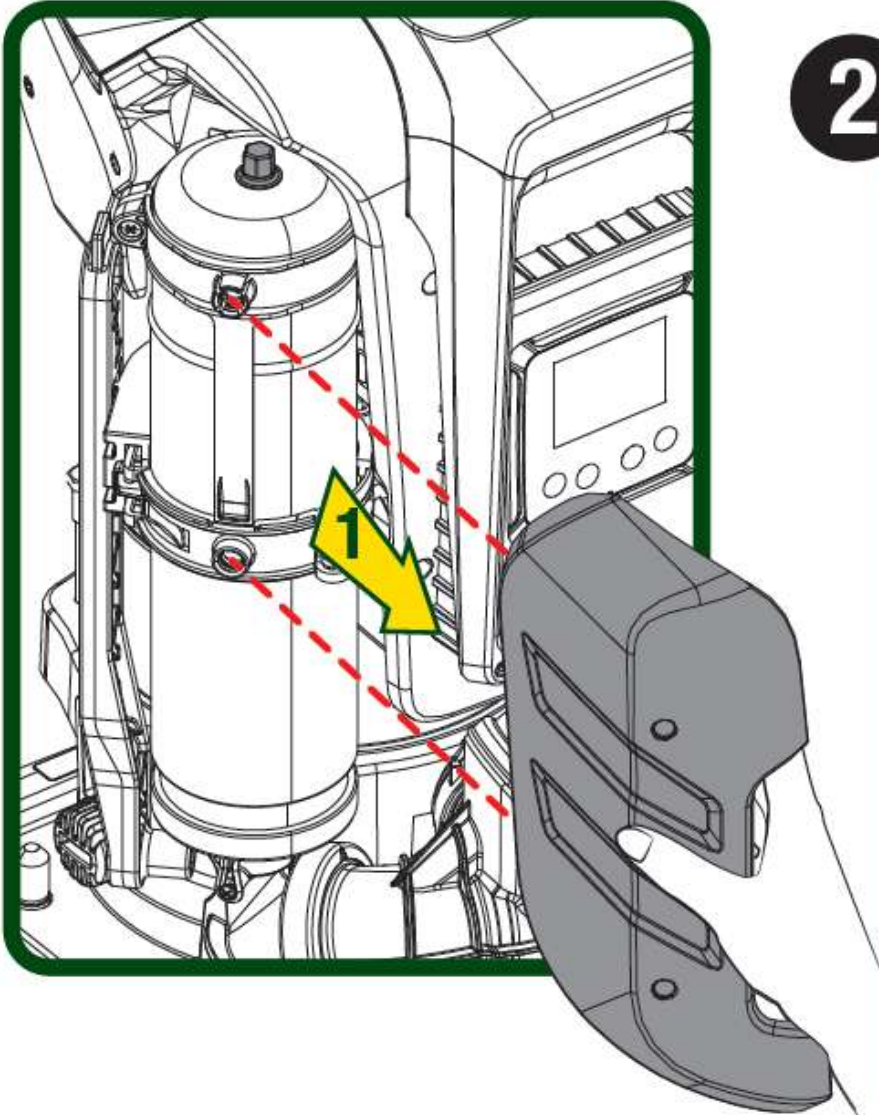

# PRIMING THE PUMP

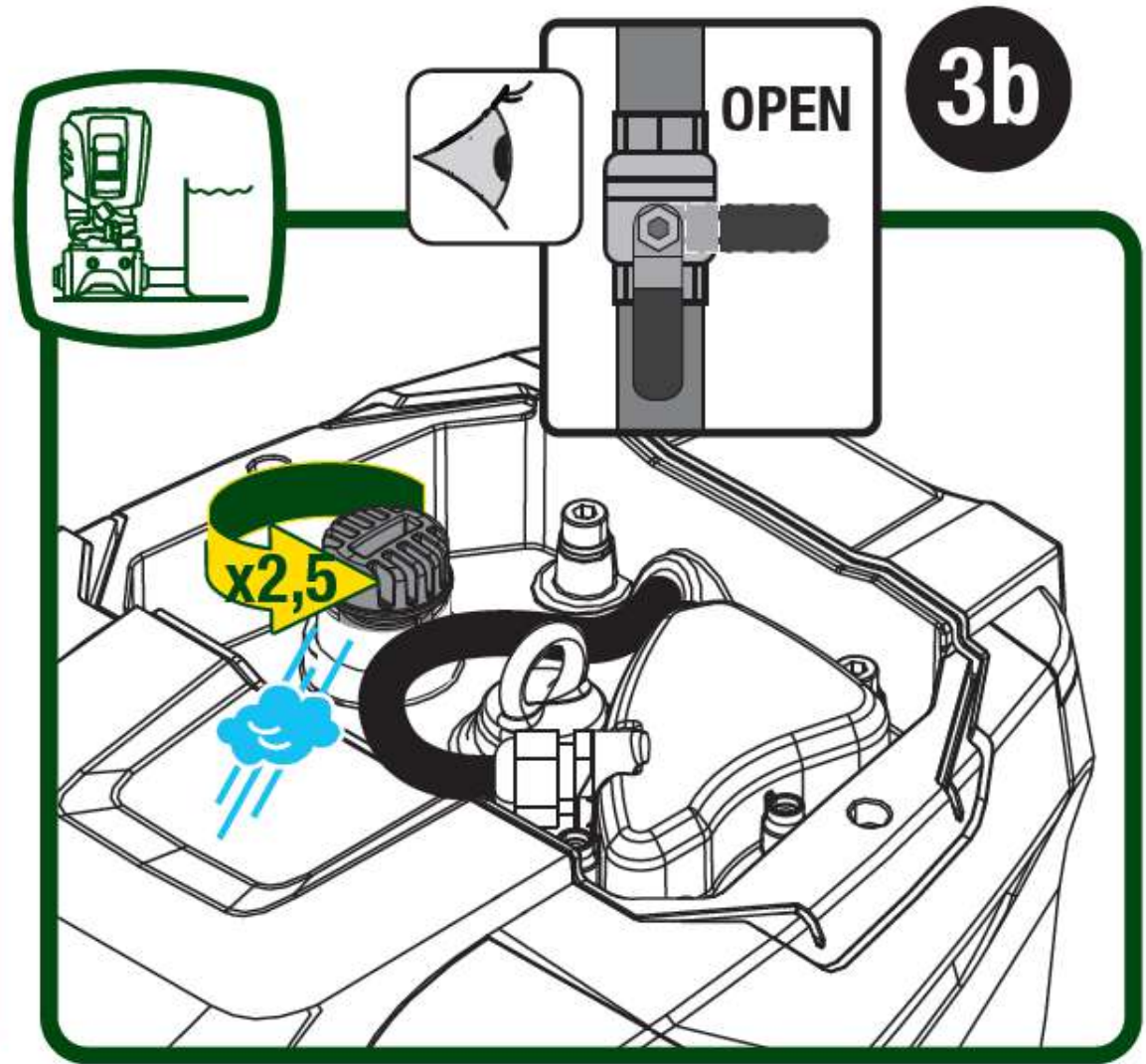
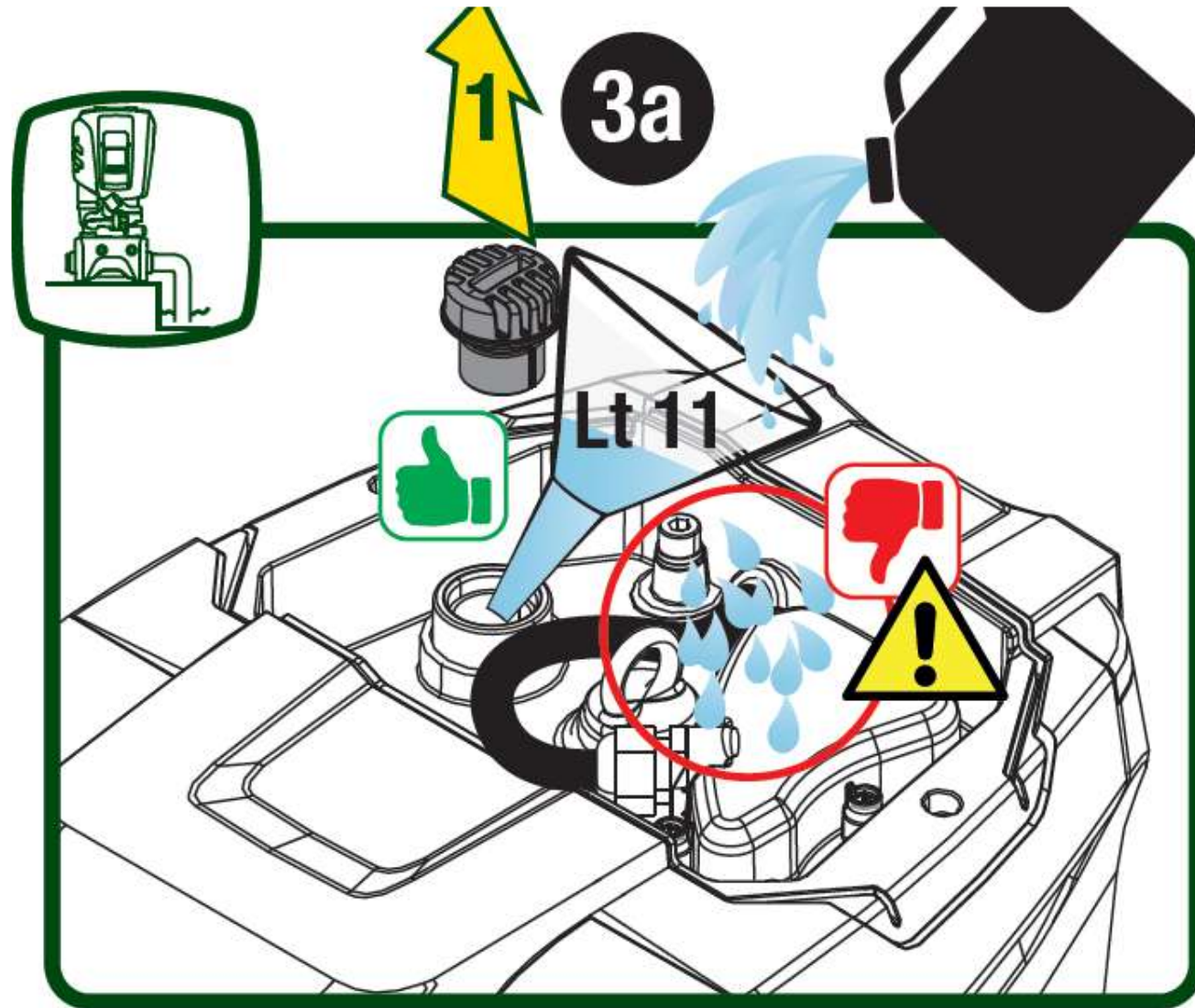

# DISPLAY



MENU NAME	DIRECT ACCESS KEYS	HOLD-DOWN TIME
User		On releasing the button
Monitor		2 Sec
Setpoint		2 Sec
Manual		5 Sec
Installer		5 Sec
Technical assistance		5 Sec
Reset factory values		2 sec after switching on appliance
Reset		2 Sec

# DISPLAY

<i>Reduced menu (visible)</i>			<i>Extended menu (direct access or password)</i>			
Main Menu	User Menu mode	Monitor Menu set-minus	Setpoint Menu mode-set	Manual Menu set-minus-plus	Installer Menu mode-set-minus	Tech. Assist. Menu mode-set-plus
MAIN (Main Page)	<b>STATUS</b>	<b>BK</b> Back lighting	<b>SP</b> Setpoint pressure	<b>STATUS</b>	<b>RP</b> Decrease pressure for restart	<b>TB</b> Block time for water lack
Menu Selection	<b>RS</b> Revs per minute	<b>TK</b> Backlighting switch-on time		<b>RI</b> Speed setting	<b>OD</b> Type of plant	<b>T1</b> Low pressure delay
	<b>VP</b> Pressure	<b>LA</b> Language		<b>VP</b> Pressure	<b>AD</b> Address Configuration	<b>T2</b> Delay in switching off
	<b>VF</b> Display of flow	<b>TE</b> Heat sink temperature		<b>VF</b> Display of flow	<b>MS</b> Measuring system	<b>GP</b> Proportional gain
	<b>PO</b> Power absorbed by pump	<b>BT</b> Card temperature		<b>PO</b> Power delivered to the pump	<b>AS</b> Wireless devices	<b>GI</b> Integral gain
	<b>C1</b> Pump phase current			<b>C1</b> Pump phase current	<b>PR</b> Remote pressure sensor	<b>RM</b> Maximum speed
	<b>TE</b> Heat sink temperature			<b>RS</b> Revs per minute	<b>EK</b> Low pressure function on suction	<b>NA</b> Active devices
	<b>Pin</b> Pressure at intake			<b>TE</b> Heat sink temperature	<b>PK</b> Low pressure threshold on suction	<b>NC</b> Max. simultaneous devices

# BOOSTER SETS



PUMP 1 PUMP 2

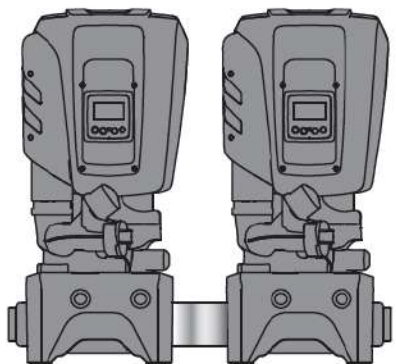

PUMP 1

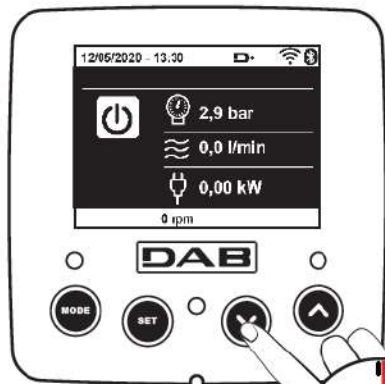

PUMP 2

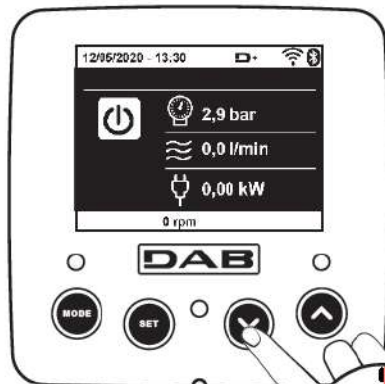



# BOOSTER SETS

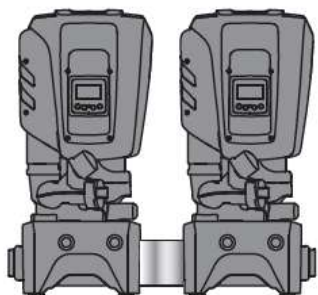

**D/A** → **NC= 2**  
**D/S** → **NC= 1**

**D = DUTY**  
**A = ASSIST**  
**S = STANDBY**

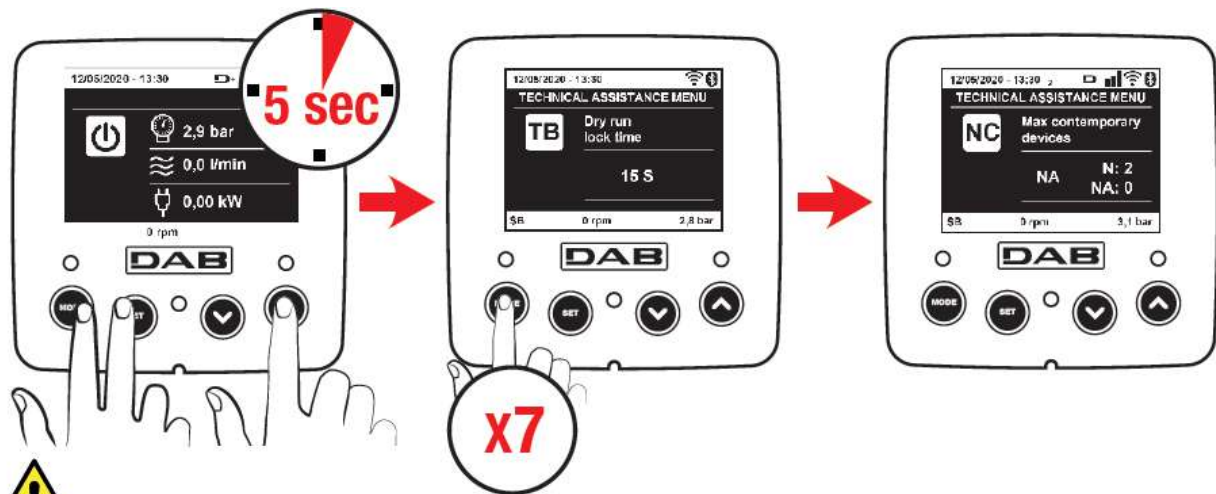

**! ACCESSORY**

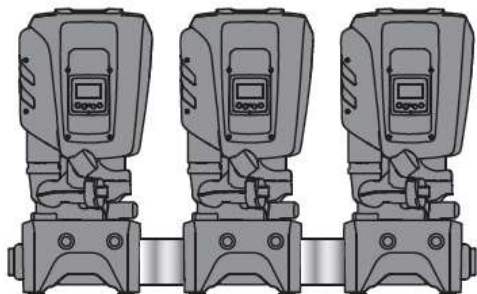

**D/A/A** → **NC= 3**  
**D/A/S** → **NC= 2**

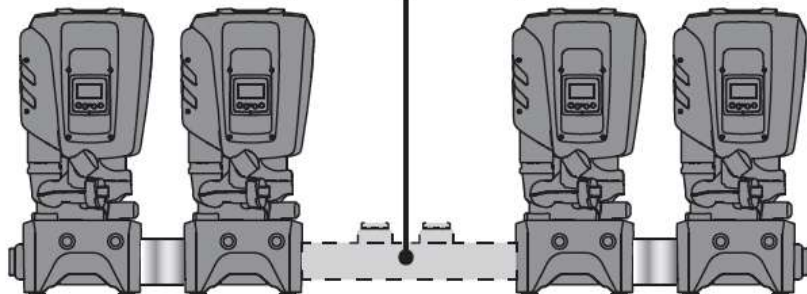

**D/A/A/A** → **NC= 4**  
**D/A/A/S** → **NC= 3**

# BOOSTER SETS



“MODE” and “SET” and “PLUS”  
FOR 3 SECONDS  
“MODE” TO SCROLL PARAMETERS  
ADJUST THE VALUE WITH “+” OR “-”  
“SET” TO CONFIRM

## WIRELESS

ON BOARD



# N

TOTAL NUMBER OF PUMPS

# # pumps

TOTAL NUMBER OF PUMPS CONNECTED IN THE SAME BOOSTER SET. N IS AUTOMATICALLY DETECTED BY EASYBOX.

# NA

ACTIVE PUMPS

# 1 ... N

TOTAL NUMBER OF PUMPS INVOLVED IN THE PUMPING SYSTEM (ACTIVE + STANDBY + RESERVE)  
IF  $NA < N$ , ONE OR MORE PUMP ARE EXCLUDED: THEY WILL BE CONSIDERED AGAIN ONLY IN CASE OF FAULT ON EASYBOX. DEFAULT:  $NA = N$ .

# NC

SIMULTANEOUS PUMPS

# 1 ... N

MAX NUMBER OF SIMULTANEOUS OPERATIONAL PUMPS, WHICH SPLIT THE WATER FLOW DEMAND.  
IF  $NC < NA$ , ONE OR MORE PUMP ARE IN STAND-BY. STAND-BY PUMPS CICLICALLY ENTER INTO OPERATION (FUNCTION ROTATION). DEAFULT:  $NC = NA$ .

# IC

RESERVE PUMPS

# 1 or 2

ANY SINGLE PUMP CAN BE CONFIGURED AS ACTIVE (IC = 1) OR RESERVE (IC = 2). WHEN A PUMP IS SET TO RESERVE, IT IS THE LOWEST IN FUNCTION PRIORITY. DEFAULT: IC = 1.

# ET

EXCHANGE TIME

# 10s ... 9h

EXCHANGE TIME TO BALANCE THE OPERATIONAL TIME BETWEEN THE DIFFERENT PUMPS OF THE BOOSTER SET. EXCHANGE CAN HAPPEN ON STAND-BY OR DURING OPERATION. IF  $ET = 0$ , AT ANY START A NEW PUMP IS FUNCTIONING. DEFAULT: 2 HOURS.



# Networking

## Wireless Communication

ESy I/O



extension  
module



# ESY I&O

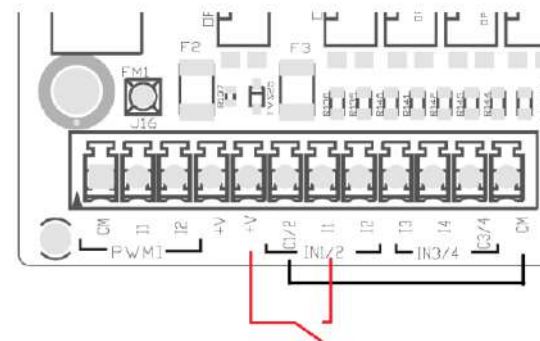
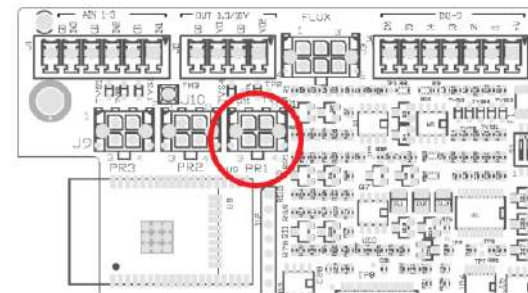
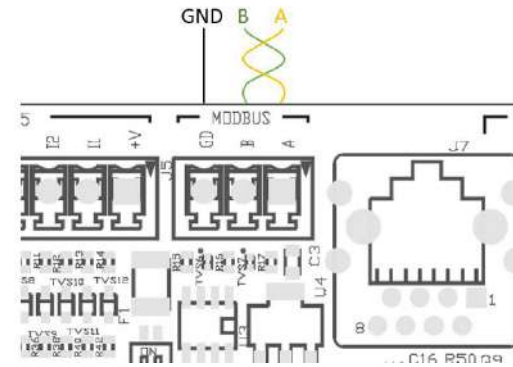
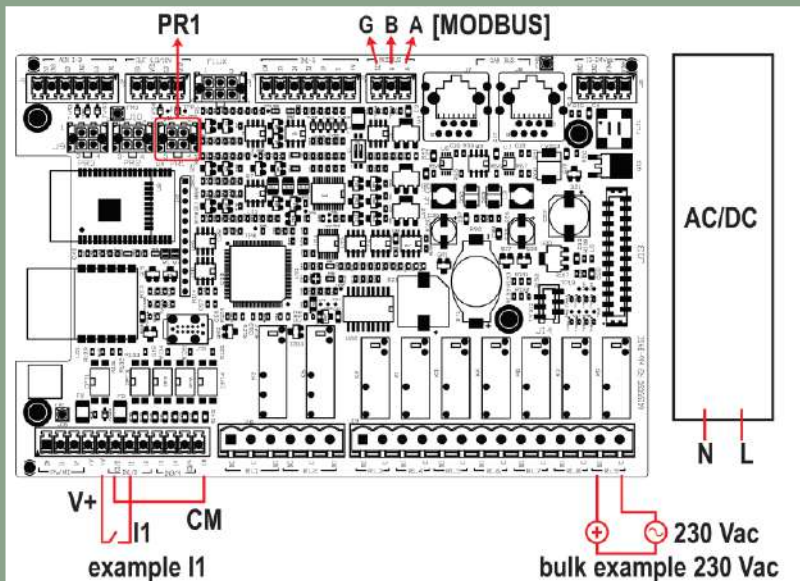

Serial Communication  
*MODBUS RS485*

Additional Set-Point  
*PRESSURE SENSORS HUBA*

Inputs / outputs  
*DIGITAL CONTACTS*

## PROTECTION PANELS



Electrical breaker panels are available as accessory for 2/3 pump sets.

The panels are supplied with a mains power lead and a feeding cable for each pump.

They can be delivered together with a support pillar kit, that's fixed on the stainless steel manifolds of the dock.



[www.dabpumps.com](http://www.dabpumps.com)

